

SEA SHORE COMMUNICATION SYSTEM USING RF SIGNAL FOR FISHERMAN SATETY

S.M.SHANGAVI¹,B.BALASUBRAMANIYAN² , B.ARUNKUMAR² J.JAGATHEESAN²

Assistant professor¹,UG student²

Dept. of Electrical and Electronics Engineering,

Sir Issac newton college of Engineering & Tech, Nagapatinmam. ,India

ABSTRACT

This paper focuses on the problem of the fisherman crossing the border and being captured by the other country navy. Also, when the weather conditions are bad, the boat losses its ability to travel over the sea and merge with the sea. The main reason behind this problem is that there is no communication between the boat and sea shore and the sea borders between the two countries are not easily identifiable. To avoid this problem, a wireless tracking based communication with boat and seashore is proposed. It also gives sufficient information about the ship and coastal guardians for border crossing by GPS tracking. The life time GPS can be extended by using block box. Hence, this paper comes with a consistent solution for this problem and protects Indian fisherman from dangerous situation and being crossing maritime boundary which saves the life and improve the safety of fisherman.

Key words fishermen, sea-shore, wireless communication, GPS.

I.INTRODUCTION

Fishing is the main occupation in which the person of the coastal region depends. Crossing the border is the serious problem that has been more often faced by all the fisher man. Once the fisher man crosses the border, they had been caught by the country navy and they are severely punished by them.

D.Jim Isaac et al [1] the paper titled as“Advanced border alert system using GPS and with intelligent Engine control unit”which proposes the system using GPS and GSM, where GPS is used to find the location of the boat. If the boat nearer to the boundary, it warns the fishermen with the alarm and emits the location of the boat to the nearest coast office by GSM communication. If it further nears the maritime boundary an interferer is sent to the Engine Control Unit which controls the speed of the engine with the help of the electronic fuel injector. . S. Kiruthika et al [2] the paper titled as “A Wireless mode of protected defence mechanism to mariners using GSM technology” that deals with the concept of the system using only GPS to receive the information from the satellite and stored border locations to detect whether the boat has crossed the border or not.

transmitted to nearby coast office through RF signals at VHF (30-300MHz) range which covers wide area. Naveen Kumar.M et al [3] the paper titled as “border alert and smart tracking system with alarm uses DGPS and GSM” and this system uses DGPS to track the location of the boat and to activate an alarm which consists of a Piezo-buzzer, when the border is move toward or crossed. Also, in addition, the DGPS information is sent to control office, and also the information is sent to the family at regular time intervals that are in expectation about their family member's safety. M.santhoshsamuel et all[4] presented a paper titled “safeguarding the fishermen on inndian maritime boarderusing GNSS and cloud computing” which makes use of cloud computing as a service and uses GNSS tonavigate in all lakes, sea and oceans in the world.

II. METHODOLOGY AND OVER VIEW

The GPS device will repetitively give the signal which determines the latitude and longitude and indicates the position of the fishermen and which gets read and displayed in the LCD.

If the mariner is alerted and the message is

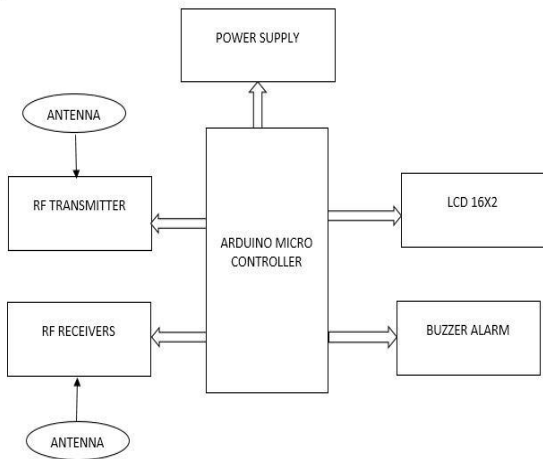

Fig.1 block diagram of transmitter

GPS provides consistent positioning, navigation, and timing services to users on a continuous basis in every day and night. Then GPS store the storage of the maritime position. While comparing the previous maritime restricted position and current position and result will be the latitude and longitudinal degree of the boat's location is determined. If the boat nearer to the restricted zone the alarm will turn on and the sound keep on increasing and also speed of the engine will get reduced by using pulse width modulation.

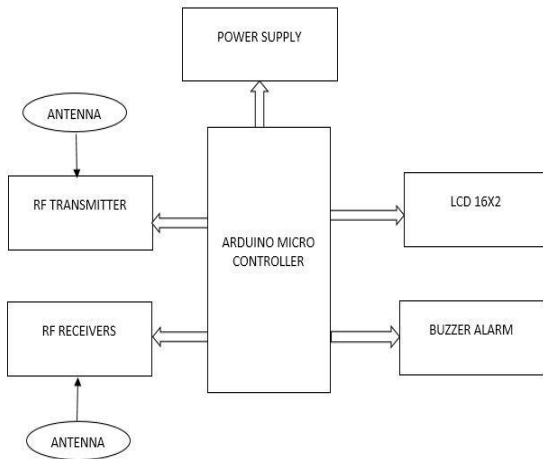

Fig.2 block diagram of receiver

In its simplest pulse width modulation output signals are constructed by comparing two signals. The signals are restricted position (carrier signal) and current position (modulation signal) pulse width modulation operating at a low power frequency. While carrier frequency higher than the modulation frequency, the alarm will keep on increasing, if the other case carrier frequency lowers than the modulation frequency, the alarm will keep on decreasing. Then the fisherman fails to ignore the warning and they move to reaches the restricted zone automatically engine gets off.

TRANSMITTER

A radio transmitter is an electronic device which, when connected to an antenna, produces an electromagnetic signal such as in radio and television broadcasting, two way communications or radar. Heating devices, such as a microwave oven, although of similar design, are not usually called transmitters, in that they use the electromagnetic energy locally rather than transmitting it to another location. This are the purpose on signal transmitted to another location. this transmitter communication RF signals on the transmitter control.

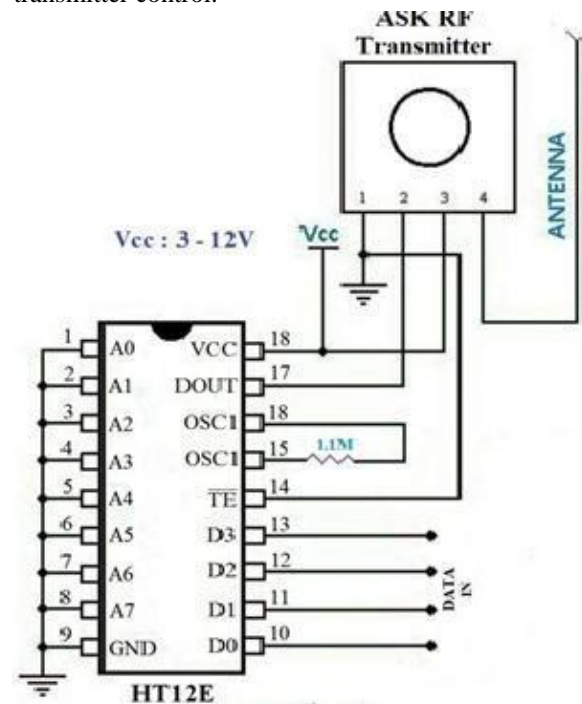

Fig.3 circuit diagram of transmitter

RECEIVERS

RF Receiver receives the data transmitted using ASK RF Transmitter.

HT12D decoder will convert the received serial data to 4 bit parallel data D0 – D3. The status of these address pins A0-A7 should match with status of address pin in the HT12E at the transmitter for the transmission of data.

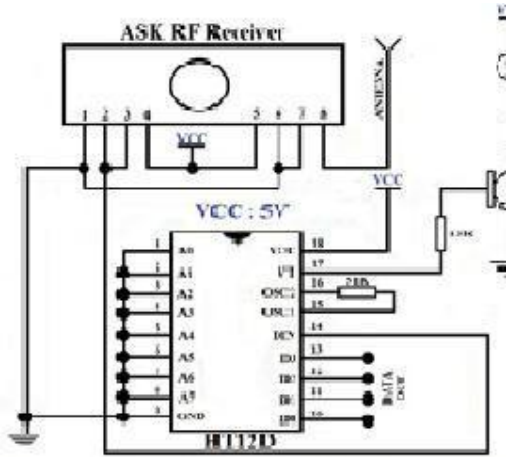

Fig.4 circuit diagram of receiver

The LED connected to the above circuit glows when valid data transmission occurs from transmitter to receiver. 51KΩ resistor will provide the necessary resistance required for the internal oscillator of the HT12D. This receiver purpose transmitter one signal another received from rf receiver signals. The received signals from get information received in RF communication on the fisherman.

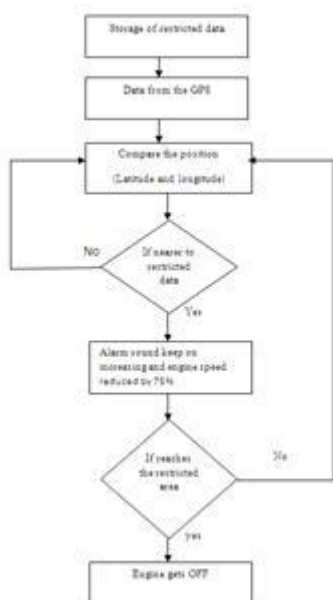

Fig.5 overall flowchart

III HARDWARE COMPONENTS

a) GPS

The Global Positioning System (GPS) is a space based navigation system that provides location and time information in all weather conditions. The GPS detects the latitude and longitude of the boat's position and sends the data to the microcontroller. This capability allows finding out whether the boat has crossed the restricted area or not. This gives the current position of the boat to the ATMEGA 328 Microcontroller in the Engine Control Unit. It compares the current position and stored restricted position if the boat is at a distance of Three kilometer from the restricted area and then processor to generate an alarm keep on increasing and also reduced the speed of the engine, The latitudes and longitudes received from the microcontroller is compared with the stored restricted area values and reaches the restricted area, the engine will get off.

b) ENGINE CONTROL UNIT

The ECU consists of an AT mega 238, random access memory (RAM), read only memory (ROM), and an input/output interface. This unit is used to stop motor when it is reaches the restricted area. If it is nearer the restricted area, the motor speed reduced by using pulse width modulation. The Electronic Control Unit (ECU) can control almost every operation in an engine together with explosion systems. In electronic control unit operate at electronic fuel injector with a solenoid valve to control the fuel supply in the engine When the alarm is generated it is necessary to stop the engine from moving forward The fuel injector is fitted with a solenoid valve which is a electromagnetically controlled mechanical valve. When the GPS position matches the stored restricted value, the result of the value give to the fuel injector. So this in turn reduced the fuel supply which stops the engine from moving forward

c) POWER SUPPLY

The power supply is provided DC motor and microcontroller. The DC power supply with both positive and negative output voltages, a center-tapped transformer is used and Arduino operates at low power.

d) RELAY

A relay is an electrically operated switch. Where many relays are used to an electromagnet to mechanically operate a

switch, but other operating principles are also used, such as solid state relays. Relays are used where it is necessary to control a circuit by a low-power signal where several circuits must be controlled by one signal. The first relays were used in long distance telegraph circuits as amplifiers they repeated the signal coming from one circuit and re-transmitted it on another circuit.

e) BUZZER

If the boat nearer to the restricted area the alarm will keep on increasing by means of pulse width modulation. It ranges from (0-255)

IV EXPERIMENTAL RESULT AND DISCUSSION

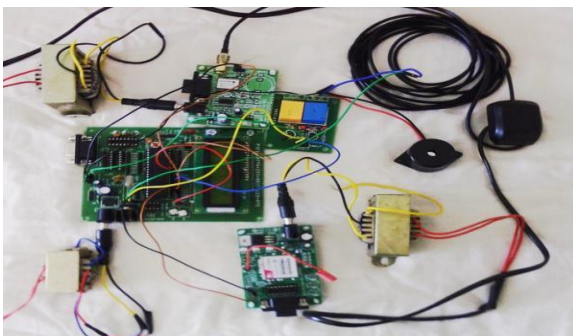

Fig.6. complete setup of working module



Fig.7. initialization of project module

This method on easy identified in cyclone and another any one formation. The arduino microcontroller is interfaced on LCD display in output form the danger zone in indicate on the measure. And the buzzer alarm from noise produced. This are next on motor speed control reduced from the restricted levels. These are easy prevented on method of low cost from the material from interfacing on arduino microcontroller. The border crossing in alert system from the controller

CONCLUSION

This paper deals with the current major problem of tamilnadu fisherman. According to this concept, every fisherman can be traced out by

Indian coastal guards and they can be safe and also to protect themselves from the other navy. Thus the loss of fishermen Life can be prevented and our ties with srilanka can improve.

REFERECE:

- [1] Jim Isaac ,“Advanced border alert system using GPS and with intelligent Engine control unit”, International Journal of Electrical and Computing Engineering (IJECE) Vol. 1, Issue. 4,June 2015
- [2] S.Kiruthika, N.Rajasekaran the paper titled as “A Wireless mode of protected defense mechanism to mariners using GSM technology” International Journal of Emerging Technology and Innovative Engineering Volume I, Issue 5, May 2015 (ISSN: 2394 – 6598).
- [3] G.Sivagnanam, A.J.Midhun, N.Krishna, G.Maria Samuel Reuben A.Anguraj “Coast guard alert and rescue system for international maritime line crossing of fisherman” International Journal of Innovative Research in Advanced Engineering (IJIRAE) ISSN: 2349-2163 Issue 2, Volume 2 , February2015.
- [4] NaveenKumar.M Ranjith.R “Border alert and smart tracking system with alarm using DGPS and GSM” International Journal of Emerging Technology in Computer Science & Electronics (IJETCSE) ISSN: 0976-1353 Volume 8 Issue 1 –APRIL 2014.
- [5] K. Suresh Kumar et. al. “Design of low cost maritime boundary identification device using gps system” International Journal of Engineering Science and Technology Vol. 2(9), 2010, 4665-4672.
- [6] http://www.thehindu.com/multimedia/dynamic/01689/TH_GROWING_rev__16899_54g
- [7] S. Mani Sunder, “Deep sea fishermen patrol system for coastal intruder positioning”Scientific Engineering and Technology (ISSN : 1581)Volume 2 Issue 3, PP : 129
- [8] GoogleMAPS
API<http://code.google.com/apis/maps>
- [9] P.Satheesh, Maritime Border Refuge System [MBR]/ National Conference on Emerging Trends in Computer, Communication & Instrumentation in Strength Security